

HAITIMA around the world

- ◆ **Taiwan**
Office &
Factories in
Tainan
- ◆ **Philippines:**
Factory
- ◆ **Canada:**
Vancouver
Office &
Warehouse
- ◆ **Holland:**
Office &
Warehouse



HAITIMA CORPORATION

8F, NO. 201, Sec. 2, Tiding Blvd., Neihu District, Taipei City 114 Taiwan.
R.O.C.

TEL:+886-2-26585800 FAX:+886-2-26582266 +886-2-27997766

E-mail: haitima@seed.net.tw

Website: www.haitima.com.tw



HTE SERIES ELECTRIC ACTUTOR



With advanced equipment, excellent technology and perfect quality management system, HAITIMA gathered team of professional and technical elite are making full use of new technologies, new processes and new materials to ensure the stability and reliability of the product. Product quality originates in advanced manufacturing; the consciousness of competitive products comes by constant innovation.

Perfect quality is
originated from advanced
manufacturing means

ENTERPRISE EQUIPMENT



CONTENTS

HTE electric actuator instructions	01
The name of the product structure and some parts	01
Product Overview	02
Performance feature	02
Model coding	02
Electric actuators main technical parameters	03
Circuit diagram	03-04
HTE 05 Overall dimensions and performance parameters	05
HTE 10 Overall dimensions and performance parameters	06
HTE 20 40 60 Overall dimensions and performance parameters	07
HTE 100 150 Overall dimensions and performance parameters	08
Installation and adjusting	09-10
Configuration and function	11-12
Product show	13-14



1. HTE electric actuator instructions

Please read the instructions before using

Before installation and usage,pls confirm as below:

- a.Packing and documents ①product list ②test report ③wiring diagram
- b.Inspection report; Nameplate; Electrical wiring diagram is consistent with purchasing order
- c.Before the end of setting Limit switch. Do not make the actuator be in full- open or full-closed
- d.After Completing of electrical wiring, to deal with cable interface in seal method.

2. The name of the product structure and some parts

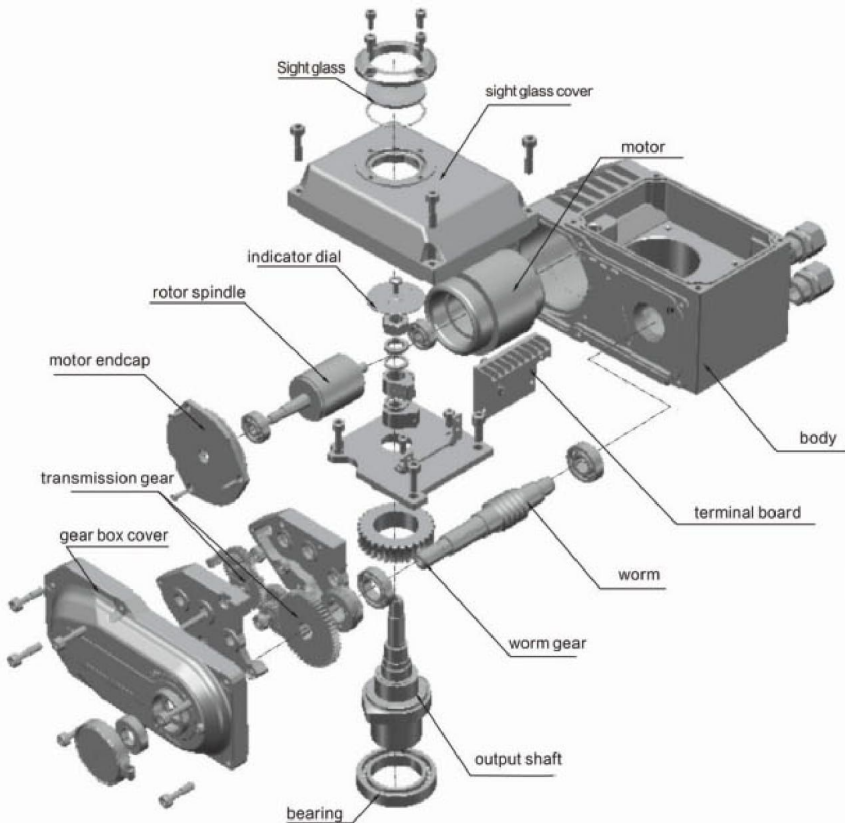

Fig1

3.Product overview

HTE series electric actuator used to control 0 ~ 270 ° rotary valve, such as butterfly valve, ball valve, throttle, baffle valves, plug valves, etc. Widely used in petroleum, chemical industry, water treatment, ship, paper, power stations, heating supply, building automation, light industry etc. 380 v / 220 v / 110 v AC power supply for driving power supply, 4-20 ma current signal, or 0 -10 VDC voltage signal to be control signal, can make the valve movement to the required position, realize automation control. Maximum output torque is 1500 N. M

4.Performance feature

- 4.1 Housing
Aluminum alloy housing,anodic oxidation process and, polyester powder coated, strong corrosion resistance, protection class is IP67.
- 4.2 Motor
Squirrel-cage motor, small size, large torque,low inertia, insulation class is F, built-in overheat protection switch, can prevent the motor from overheating.
- 4.3 Manual operation
Safe and reliable handle design is very easy for manualoperate.But make sure the power is "OFF" before manual operation.When the handle is free,put it in the socket beside the body for keeping.
- 4.4 Indicator
Indicator is installed on the central axis, showing valve position. The convex lens design make it more easier to observation and no waterlogging .
- 4.5 Dryer
Dryer is used to control the temperature and avoid actuator internal moisture condensation caused by temperature or weather changes .To keep the electric elements dry.
- 4.6 Seal
Good seals.Standard product protection grade is IP67, and optional IP68 .
- 4.7Limit switch
Mechanical and electronic double position limit. Mechanical limit screw is adjustable, safe and reliable; Electronic limit switch controlled by cam mechanism, easy adjusting the cam can set position accurately and conveniently, and is not affected by excess hand operation.
- 4.8 Self-locking
The high precision worm and gear mechanism has high effectively transfer and output large torque. And it's self-locking function, prevent reverse. transmission part is stable and reliable , no need more grease.
- 4.9 Anti-off bolt
When remove the cover,the bolt attached to the shell, will not fall off.
- 4.10 Installation
The bottom connection is according to ISO5211 / DIN3337. Can be installed in both vertical and horizontal installation.
- 4.11 Circuit
Control circuit conforms to single or three-phase power supply standard, circuit layout is reasonable, compact .terminals can effectively satisfy a variety of additional functional requirements.

5.Model coding

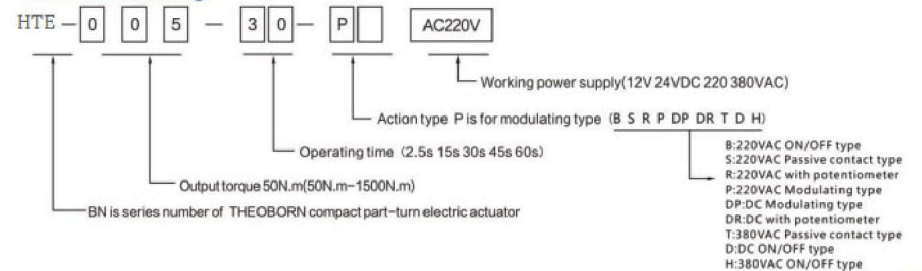

6. Electric actuators main technical parameters

HTE series electric actuator output torque ranges from 50 N. m to 1500 N. m, fit a variety of rotary valve, (ball valve, utterfly valve, etc.) and damper baffle, etc.

Model	HTE-03	HTE-05	HTE-08	HTE-10	HTE-20	HTE-40	HTE-60	HTE-100	HTE-150	
Performance										
Output Torque	30N.m	50N.m	80N.m	100N.m	200N.m	400N.m	600N.m	1000N.m	1500N.m	
operating time	30s/40s	30s	30s/40s	20s/30s/60s	15s/30s/60s	15s/30s/60s	30s/60s	30s/45s/60s	45s/60s	
Rotary Angle	0-270 °for option									
Motor power	20W	20W	20W	25W	40W	90W	120W	120W	140W	
Standard fit valve	ball valve	DN15-32	DN15-40	DN50	DN50-65	DN100	DN125	DN125-150	DN200	DN250
	butterfly valve	DN40-50	DN65-80	DN100	DN65-125	DN200-250	DN300-350	DN400-450	DN500	DN600
Power Supply	DC24V/AC24V AC110V/AC220V/AC380V									
Insulation Resistance	DC24V/AC24V 100MΩ/250VDC AC110V/AC220V/AC380V 100MΩ/500VAC									
Withstand Voltage	DC24V/AC24V 500VDC 60S AC110V/AC220V/AC380V 1500VDC 60S									
Protection Class	IP67									
Counduit Entry	2xM18x1.5CABLE GLAND									
Protective Device	(automatic recover type)thermal protector									
Limit Switch	electric work:close/open limit switch manual work: mechanical limit									
Installation Location	at any angle									
Ambient Temperature	-20°C~60°C									

Note: The above valve-actuator sizing table is only for reference.some special requirements such as travel time and the turning Angle can be customized according to customer's requirements.

7. Circuit diagram

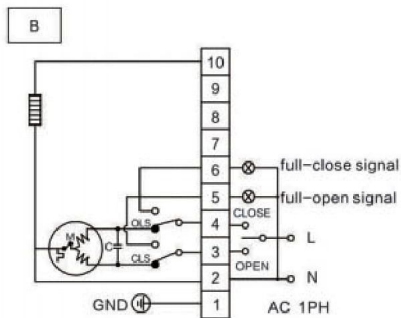

220VAC Standard ON/OFF type circuit diagram
Alternating Current realize startup, shut down action,
and output a set of instructions "full-close signal"
"full-open signal" active position signal.

Fig2

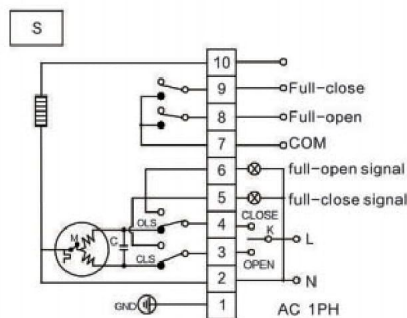

220VAC output Passive contact signal circuit diagram

Fig3

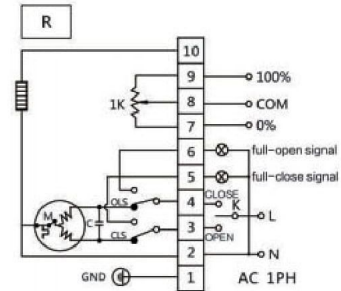

220VAC ON/OFF type (with potentiometer)
Through the switch circuit to control valve opening angle with corresponding potentiometer resistance value, and at the same time realizing mid-position function.(with 1KΩ and mid-position switch)

Fig4

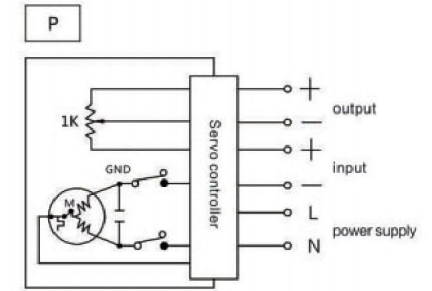

220VAC modulating type circuit diagram
Through external industrial instrument output standard signal, adjust and control actuators open-close Angle, and output 4-20 mA feedback signal of valve position.

Fig5

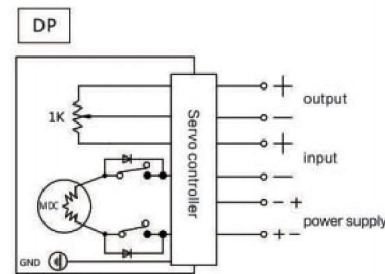

DC modulating type circuit diagram

Fig6

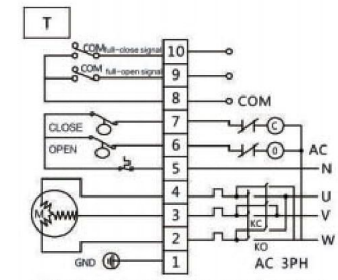

380VAC standard type output passive contact signal circuit diagram

Fig7

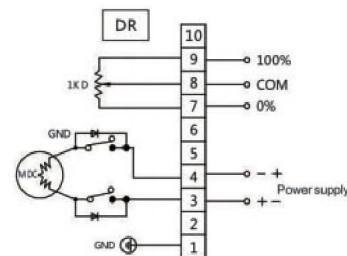

DC Circuit diagram (with potentiometer)

Fig8

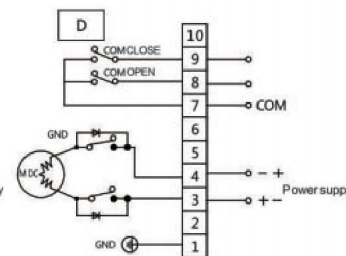

DC ON/OFF TYPE Circuit diagram

Fig9

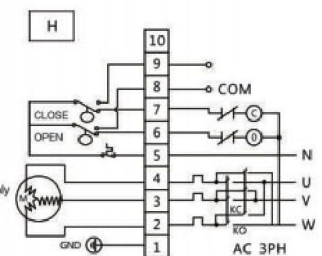

380VAC ON/OFF type circuit diagram

Fig10

8. HTE 05 Overall dimensions and performance parameters

Model	HTE-05					
Power supply	DC12V	DC24V	AC24V	AC110V	AC220V	AC380V
Motor power	20W			23W		
Rated current	2A	1.2A	0.8A	0.7A	0.35A	0.2A
Output torque	30N.m/50N.m			15N.m/30N.m/50N.m		
Operating time	20S/30S/40S/60S for option					
Action type	B S R P DP DR T D H					
Rotary Angle	0-270° for option					
Withstand voltage	DC24V/AC24V	500VDC	60S	AC110V/AC220V/AC380V	1500VDC	60S
Insulation resistance	DC24V/AC24V	100MΩ/250VDC	AC110V/AC220V/AC380V	100MΩ/500VAC		
Protection class	IP67					
Conduit entry	2xM18x1.5CABLE GLAND					
Protective device	(automatic recover type) thermal protector					
Limit switch	Electric work: close/open limit switch Manual work: mechanical limit					
Installation location	At any angle					
Working temperature	-20°C ~ 60°C					
Material of body	Aluminium alloy					

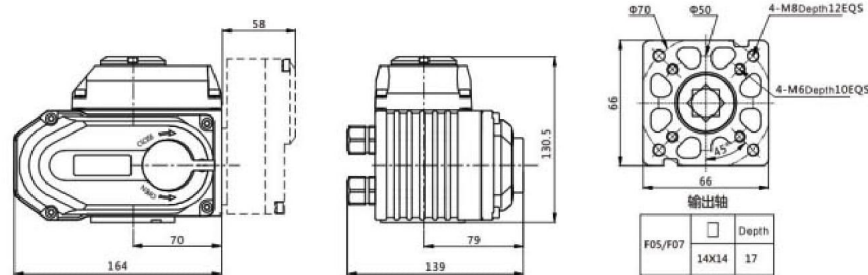

Fig11

Model	Output torque	90° operating time of	Power supply	Soft seal butterfly valve	Ball valve	Aeration butterfly valve
			AC110V, AC220V AC380V, DC24V	≤PN1.6MP		≤0.1MP
HTE-05	50N.m	30S		≤DN80	≤DN32	≤DN80

9. HTE10 Overall dimensions and performance parameters

Model	HTE-10					
Power supply	DC12V	DC24V	AC24V	AC110V	AC220V	AC380V
Motor power	40W			25W		
Rated current	2.4A	1.5A	0.8A	0.75A	0.45A	0.25A
Output torque	50N.m/100N.m			50N.m/80N.m/100N.m		
Operating time	15S/20S/30S/40S for option					
Action type	B S R P DP DR T D H					
Rotary Angle	0-270° for option					
Withstand voltage	DC24V/AC24V	500VDC	60S	AC110V/AC220V/AC380V	1500VDC	60S
Insulation resistance	DC24V/AC24V	100MΩ/250VDC	AC110V/AC220V/AC380V	100MΩ/500VAC		
Protection class	IP67					
Conduit entry	2xM18x1.5CABLE GLAND					
Protective device	(automatic recover type) thermal protector					
Limit switch	Electric work: close/open limit switch Manual work: mechanical limit					
Installation location	At any angle					
Working temperature	-20°C ~ 60°C					
Material of body	Aluminium alloy					

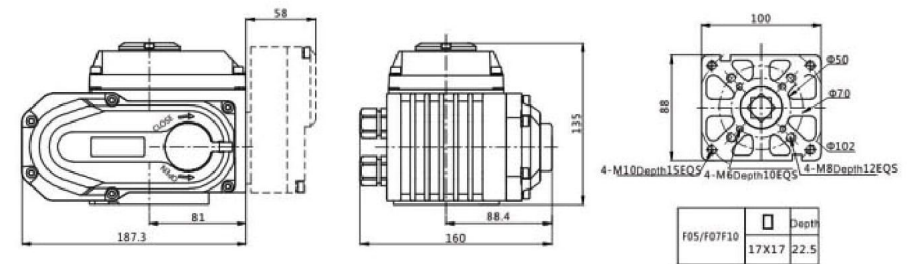

Fig12

Model	Output torque	Operating Time of 90°	Power supply	butterfly valve	butterfly valve	Ball valve	butterfly valve
			AC110V, AC220V AC380V, DC24V	≤PN1.6MP		≤0.1MP	
HTE-10	50N.m	15S		≤DN80	≤DN32	≤DN80	
	100N.m	30S		DN32-DN65	DN80-DN125	DN40-DN65	DN100-DN200

10. HTE 20 40 60 Overall dimensions and performance parameters

Model	HTE-20				HTE-40				HTE-60			
	Power supply	DC24V	AC110V	AC380V	AC220V	DC24V	AC110V	AC380V	AC220V	DC24V	AC110V	AC380V
Motor power	35W	40W	30W	40W	60W	90W	40W	40W	60W	90W	40W	90W
Rated current	3.5A	0.65A	0.15A	0.35A	5.2A	1.2A	0.3A	0.58A	6.2A	1.2A	0.3A	0.6A
Output torque	200N.m				400N.m				600N.m			
Operating time	15S 30S 45S for option											
Action type	B S R P DP DR T D H											
Rotary Angle	0-270°for option											
Withstand voltage	DC24V/AC24V 500VDC 60S				AC110V/AC220V/AC380V 1500VDC 60S							
Insulation resistance	DC24V/AC24V 100MΩ/250VDC				AC110V/AC220V/AC380V 100MΩ/500VAC							
Protection class	IP67											
Conduit entry	2xM18x1.5CABLE GLAND											
Protective device	(automatic recover type) thermal protector											
Limit switch	Electric work:close/open limit switch Manual work: mechanical limit											
Installation location	At any angle											
Working temperature	-20°C~60°C											
Material of body	Aluminium alloy											



11. HTE 100 150 Overall dimensions and performance parameters

Model	HTE-100			HTE-150		
	Power supply	AC110V	AC380V	AC220V	AC110V	AC380V
Motor power	120W	90W	120W	140W	100W	140W
Rated current	1.95A	0.5A	0.95A	1.75A	0.46A	0.98A
Output torque	1000N.m			1500N.m		
Operating time	45S 60S for option					
Action type	B S R P DP DR T D H					
Rotary Angle	0-270°for option					
Withstand voltage	AC110V/AC220V/AC380V 1500VDC 60S					
Insulation resistance	AC110V/AC220V/AC380V 100MΩ/500VAC					
Protection class	IP67					
Conduit entry	2xM18x1.5CABLE GLAND					
Protective device	(automatic recover type) thermal protector					
Limit switch	Electric work:close/open limit switch Manual work: mechanical limit					
Installation location	At any angle					
Working temperature	-20°C~60°C					
Material of body	Aluminium alloy					

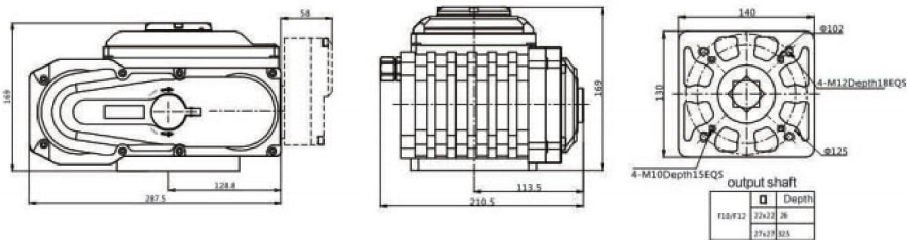

Fig13

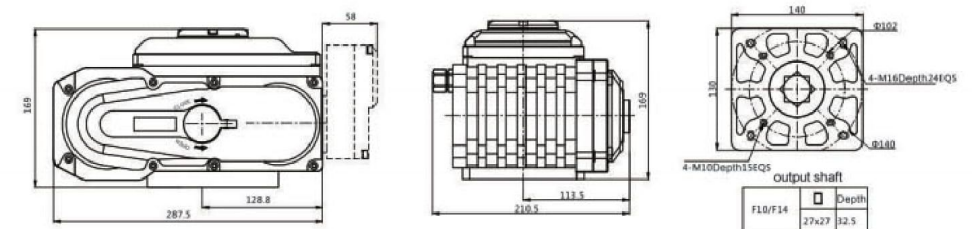

Fig14

Model	Output torque	operating time of 90°	Power supply	butterfly valve	butterfly valve	Ball valve	Aeration butterfly valve
			AC110V, AC220V AC380V, DC24V	≤PN1.6MP			≤0.1MP
HTE/20/40/60	200/400/600N.m	15S.30S.45S		DN80/DN125/DN200	DN150/DN200/DN250	DN65/DN80/D125	DN250/DN350/DN400

Model	Output torque	operating time of 90°	Power supply	butterfly valve	butterfly valve	Ball valve	Aeration butterfly valve
			AC110V, AC220V AC380V, DC24V	≤PN1.6MP			≤0.1MP
HTE/100/150	1000/1500N.m	45S.60S		DN200/DN250	DN250/DN350	DN150/DN250	DN350/DN500

12. Installation and adjusting

1-INSTALLATION

- 1) This product is not explosion-proof. Do not use it in the environment with flammable gas or corrosive gas.
- 2) Installed in a water flooded and outdoor please explain in advance;
- 3) Please reserve wiring, maintenance space such as for manual operation.
- 4) In order to avoid the rain, direct sunlight, need to install the protection cover, or chooses IP68 protection level.
- 5) Basic installation direction to keep the window to the top, the vertical pipeline actuators installation, cable interface to the ground.

2-AMBIENT TEMPERATURE, MEDIUM TEMPERATURE

Working temperature: -30°C~+60°C

When the environment temperature is below freezing, add desiccant heater inside the actuator.

When fluid temperature is below zero, the bracket connected with the valve shall special process.

Standard bracket: When fluid temperature is below + 65 °C, use standard bracket or without bracket.

Middle temp bracket: When fluid temperature is above+ 65 °C, use middle temp bracket.

High temp bracket: When fluid temperature is above+ 180 °C, use high temp bracket.

3-ASSEMBLY WITH VALVE

Assembly procedure

1. Be sure that power is off before making manual operation.
 2. Confirm that a valve is smoothly turnable by hands without eccentricity, then position it at full close.
- Note: There are some valves designed in reverse direction of open/close.
3. Bolt a bracket on the valve.
 4. Tentatively mount an actuator on the bracket with loose bolts.
 5. Position the actuator at 0 (close), joint the output shaft and the valve stem with couplings.
 6. Screw up the bolts.
 7. Check with the attached crank handle if the valve is turnable smoothly without eccentricity.

Actuator is in accordance with ISO5211 standard, if the valve is also conform to the standard, it is convenient to be connected; if not, we need to assembly bracket

4-ADJUSTMENT

1) Adjustment of Stroke limit (Figure 15,17)

Turn around handwheel to make sure the valve be in the full - closed position. To loosen nuts on cam and rotate cam to adjust the limit Switch (CLS) position and then screw limit camnut. It is the way to set the full-closed stroke limit position of a. Full-open position is set as the same way.

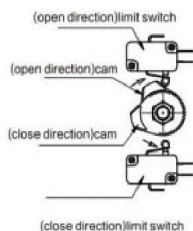

Fig 15

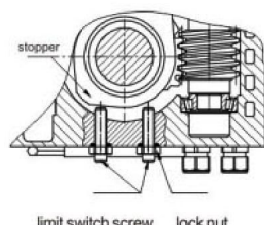

Fig 16

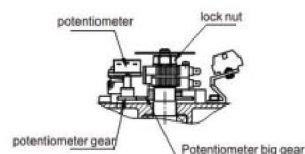

Fig 17

2) Adjustment of mechanical limit

Loosen nut mechanical limit and then make sure the actuator move to the full-closed position. Rotating limiting nuts, then stop rotate when it comes across the fan-shaped gear inside and then screw out two circles and screw the nuts at last. It is the way to set the full-closed mechanical position. Full-open position is set as the same way. Shown in Figure 16

3) Adjustment of potentiometer

Potentiometer is used for feedback signal in the actuators with three terminals. ②side connecting with slide arm of potentiometer. ①side connecting with terminal which resistance between slide arms constantly decrease, when the actuator is open. ③side connecting with terminal which resistance between slide arms constantly increase, when the actuator is closed (Note: The resistance should not over-zero, jumping phenomenon). Rotating valve to the full open position as per open to limit switch action, measured with a multimeter, to adjust the resistance to 35 Ω - 60 Ω. If it is not correct by rotating potentiometer gear to adjust (Figure 17)

5-TEST OPERATION

1) Manual Operation

Cut power off before making manual operation. Insert the manual handle into the hexagonal hole underneath the rubber cap.

Note: Opening to Full-open and full-closed position, after the limit Switch turns half circle, it will come across mechanical block. If rotate excessively, it would result the damage of other parts, So it should be avoided excessive force.

2) Power operation

Before making power operation:

- * Confirm that the indication on the position meter and the valve opening are matching each other.
- * Confirm that the circuits are properly wired, also that the unit operates in correct direction with external switches.

- 1) Check the wiring diagram, power supply, input/output signal correctly.
- 2) Don't change the internal wiring
- 3) Please check the rotating direction if the power supply is three-phase
- 4) Make sure the actuator be in the on/off position, turn on the power and input the open signal
- 5) If the actuator runs to the open direction, it means the wiring is correct.
- 6) If not, it must be changed 2 wiring lines of the 3 wiring line.

6-MAINTENANCE & LUBRICATION

As the major parts of the products are lubricated with long life by Molybdenum base grease before shipment. Lubrication is in principle not required.

When re-starting operation after a long period of rest, make the following confirmation.

- * Cut power off, confirm by manual operation that valve moves smoothly without eccentricity.
 - * Open body cover and check if there is no condensation inside the unit, also no problem on wiring.
- Note: After checking, secure the cover to prevent water ingress.

Please refer to the specification of Actuator module parts for modulating instructions.

13.CONFIGURATION AND FUNCTION High-performance intelligent module

High-performance intelligent module The intelligent control signal acquisition module adopts single-chip microcomputer as the core,with signal acquisition, processing, feedback and control into an organic whole.Which has advanced hybrid integrated circuit, good stability and control precision up to 1/1000. Small volume, convenient installation, simple operation.



Manual operation

Each BN series actuators will be equipped with a handle.When site control is power failure,user can use the handle to drive valve.



Electrical and mechanical limit function

Electrical limit function: when actuator reaches full open and close limit position, built-in electrical limit switch will cut off the circuit and protect the actuator.

Output shaft mechanical limit function: when the electric limit function fails, the actuator output shaft will be locked by mechanical limit switch, so as to protect the valve from damage.picture shows the position relation of the electrical limit and the mechanical limit.

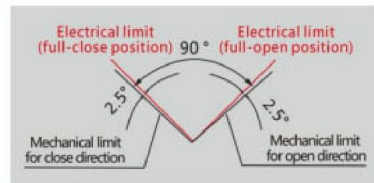

Over load torque protection function (optional)

When the valve is running (middle position) and be stuck because of the impurity in the pipeline or for other reasons,the output torque of actuators will increase rapidly.When torque reach a value (jumping machine torque), torque switch will cut off the circuit, so as to protect the valve and actuator from damage.

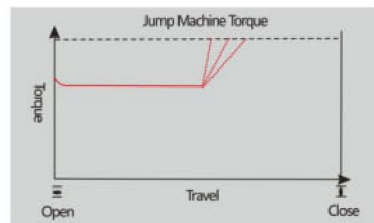

Heat dehumidification function (optional)

BN series actuators electric chamber can be configured PTC electronic heating element, for the damp place which has big temperature difference between day and night.The heater will prevent the electrical components from the damage caused by condensation.Heater is with continuous duty, so it is always at charged state, even if the actuators is stopped.

ON/OFF type actuator A, B, F, G, H control circuit

ON/OFF type actuator has only full open and full close limit position.Actuator drive valve to full open and full close when it receives the instruction.

S2 short work, continuous operation time shall be not more than 15 minutes.

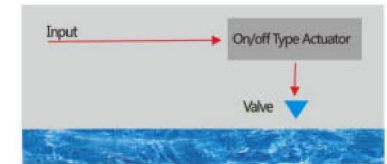

Feedback type actuator C, D type control circuit

When actuators in the process of driving the valve,it send feedback signal of valves to the central control system at the same time. C type feedback resistance signal of valve, D type feedback analog valve position signal.

S2 short work, continuous operation time shall be not more than 15 minutes.

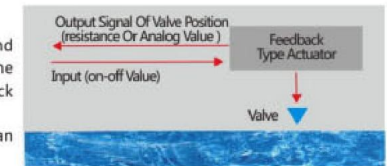

Intelligent modulating type actuator E type control circuit

Intelligent module which built-in the actuators, according to the central pipe controlled variables (flow, pressure, temperature, liquid level) and accept the instruction of the control system to drive the valve to the right opening position.

Adopt S4 intermittent type work, working frequency of up to 1200 times per hour.

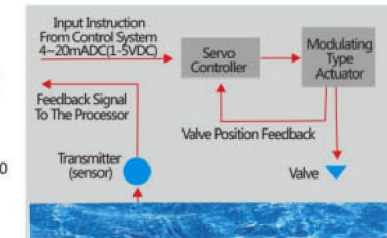

The motor

The working characteristics of the valve request the actuator have full launch ability all every position,both the valve open ,valve close and middle position. Which requires the actuator motor has high start torque.At the same time with the need of flow rate (opening), require motor must also have smaller moment of inertia.BN series electric actuators adopts special design to meet these requirements.

When the actuator is blocked, the motor temperature will rise quickly.When the motor temperature rise up to 125 °C,The overheat protector PTC(built-in motor winding) will cut off the circuit, thus protecting motor and control system.When the motor temperature dropped to 90-105 °C, the circuit will be restored.

